

L'Enseignement Mathématique

Hausmann, Jean-Claude / Knutson, Allen

POLYGON SPACES AND GRASSMANNIANS

L'Enseignement Mathématique, Vol.43 (1997)

PDF erstellt am: Sep 20, 2009

Nutzungsbedingungen

Mit dem Zugriff auf den vorliegenden Inhalt gelten die Nutzungsbedingungen als akzeptiert. Die angebotenen Dokumente stehen für nicht-kommerzielle Zwecke in Lehre, Forschung und für die private Nutzung frei zur Verfügung. Einzelne Dateien oder Ausdrücke aus diesem Angebot können zusammen mit diesen Nutzungsbedingungen und unter deren Einhaltung weitergegeben werden. Die Speicherung von Teilen des elektronischen Angebots auf anderen Servern ist nur mit vorheriger schriftlicher Genehmigung des Konsortiums der Schweizer Hochschulbibliotheken möglich. Die Rechte für diese und andere Nutzungsarten der Inhalte liegen beim Herausgeber bzw. beim Verlag.

SEALS

Ein Dienst des *Konsortiums der Schweizer Hochschulbibliotheken*
c/o ETH-Bibliothek, Rämistrasse 101, 8092 Zürich, Schweiz

retro@seals.ch

<http://retro.seals.ch>

POLYGON SPACES AND GRASSMANNIANS

by Jean-Claude HAUSMANN and Allen KNUTSON *)

ABSTRACT. We study the moduli spaces of polygons in \mathbf{R}^2 and \mathbf{R}^3 , identifying them with subquotients of 2-Grassmannians using a symplectic version of the Gel'fand-MacPherson correspondence. We show that the bending flows defined by Kapovich-Millson arise as a reduction of the Gel'fand-Cetlin system on the Grassmannian, and with these determine the pentagon and hexagon spaces up to equivariant symplectomorphism. Other than invocation of Delzant's theorem, our proofs are purely polygon-theoretic in nature.

1. INTRODUCTION

Let ${}^m\tilde{\mathcal{P}}^k$ be the space of m -gons in \mathbf{R}^k up to translation and positive homotheties (precise definitions in §2). This space comes with several structures: an action of $O(k)$, an action of S_m permuting the edges, and a function $\ell : {}^m\tilde{\mathcal{P}}^k \rightarrow \mathbf{R}^m$ taking a polygon ρ to the lengths of its edges (once the perimeter of ρ is fixed). The quotients of ${}^m\tilde{\mathcal{P}}^k$ by SO_k (or O_k) are the moduli spaces ${}^m\mathcal{P}_+^k$ (respectively, ${}^m\mathcal{P}^k$). Fixing a reflection in $O(k)$ provides an involution on ${}^m\tilde{\mathcal{P}}^k$ and ${}^m\mathcal{P}_+^k$ whose fixed point sets are ${}^m\tilde{\mathcal{P}}^{k-1}$ and ${}^m\mathcal{P}^{k-1}$. The goal of this paper is to understand the topology of these various spaces and the geometric structures that they naturally carry when $k = 2$ or 3 . They are closely related to more familiar objects (Grassmannians, projective spaces, Hopf bundles, etc.) The spaces ${}^m\mathcal{P}^k(\alpha) := \ell^{-1}(\alpha)$ of polygons with given side-lengths $\alpha \in \mathbf{R}^m$ are of particular interest.

The great miracle occurs when $k = 3$, because \mathbf{R}^3 is isomorphic to the space $I\mathbf{H}$ of pure imaginary quaternions, and the 2-sphere in \mathbf{R}^3 is Kähler. The tools of symplectic geometry can then be used. Most prominent is a

*) Both authors thank the Fonds National Suisse de la Recherche Scientifique for its support.

symplectic version of the Gel'fand-MacPherson correspondence identifying the spaces ${}^m\mathcal{P}^3(\alpha)$ as symplectic quotients of the Grassmannian of 2-planes in \mathbf{C}^m . Earlier occurrences of symplectic geometry in the study of polygon spaces can be found in [K1] and [KM2].

While this paper illustrates many phenomena in symplectic geometry, the proofs are entirely polygon-theoretic and involve only classical differential topology. Nonetheless, many of the examples are new, interesting in their own right and instructive for both fields.

Among our results :

1. The identification of the polygon space ${}^m\mathcal{P}^3$ with $\mathbf{G}_2(\mathbf{C}^m)/(U(1)^m)$ intertwines complex conjugation on the complex Grassmannian (with fixed point set the real Grassmannian) and spatial reflection on the polygon moduli space (with fixed point set planar polygons). The fact that 3-dimensional and planar polygons have the same allowed values of ℓ is then an illustration of a theorem of Duistermaat ([Du]). (As is always true, and yet always mysterious, it is helpful for studying the real case — here planar polygons — to extend to the complex case — here polygons in \mathbf{R}^3 .)

2. Identification of the densely defined “bending flows” ([K1] and [KM2]) on the polygon spaces with the reduction of the Gel'fand-Cetlin system [GS1] on the Grassmannian.

3. In some cases, the bending flows are globally defined, and by Delzant's reconstruction theory the spaces are equivariantly symplectomorphic to toric varieties (for instance when $m \leq 6$, as noted in [KM2]). We give a precise description of the moment polytope and so explicitly identify the toric varieties.

Contrary to the usual custom in symplectic reduction, it turned out here to be more natural to take symplectic quotients by *first* quotienting the original manifold by the group, and to *then* pick out a symplectic leaf of the resulting Poisson space — the intermediate quotient spaces all have natural polygon-theoretic interpretations. However, they are never complex; readers wishing a more geometric-invariant-theoretic construction of these spaces should look at [KM2].

This paper is structured as follows. Section 2 gives the definitions and elementary properties of polygon spaces. Sections 3 and 4 relate them to Grassmannians, and prove some facts about the moment map for the torus action on the Grassmannian by polygon-theoretic means. In section 4 is also calculated the exact relation between the Kähler structures in this paper and the ones in [KM2]. Section 5 relates the “bending flows” of [K1] and [KM2] with the Gel'fand-Cetlin system on the Grassmannian. Section 6 uses this to

calculate the quadrilateral, pentagon and hexagon spaces. Section 7 lists some open problems.

The study of the polygon spaces will be pursued in a forthcoming paper [HK] in which we shall compute the cohomology ring of these spaces.

The first author was incited by Sylvain Cappell to introduce symplectic geometry in his study of polygon spaces. He is also grateful to Lisa Jeffrey and Michèle Audin for useful conversations. The two authors started this work at the workshop in symplectic geometry organized in Cambridge by the Isaac Newton Institute (Fall 1994). The second author would like to thank Richard Montgomery for teaching him about dual pairs, and Michael Thaddeus for pointing out the link to moduli spaces of flat connections; also the University of Geneva for its hospitality while this paper was being written.

2. THE POLYGON SPACES

(2.1) Let V be a real vector space and m a positive integer. Let ${}^m\mathcal{F}(V)$ be the real vector space of all maps $\rho: \{1, 2, \dots, m\} \rightarrow V$ such that $\sum_{j=1}^m \rho(j) = 0$. An element $\rho \in {}^m\mathcal{F}(V)$ will be regarded as a closed polygonal path in V

$$0 \bullet \rightarrow \bullet \rho(1) \bullet \rightarrow \bullet \rho(1) + \rho(2) \bullet \rightarrow \bullet \dots \bullet \rightarrow \bullet \sum_{j=1}^m \rho(j) = 0$$

of m steps, or, alternately, as a configuration in V (up to translation) of a polygon of m sides. We shall call an element $\rho \in {}^m\mathcal{F}(V)$ an m -*polygon* (in V) and a *proper polygon* when $\rho(j) \neq 0 \forall j$. We use the notation ${}^m\mathcal{F}^k$ for the space ${}^m\mathcal{F}(\mathbf{R}^k)$.

The group \mathbf{R}_+ of positive homotheties of V acts freely and properly on ${}^m\mathcal{F}(V) - \{0\}$. The quotient ${}^m\tilde{\mathcal{P}}(V) := ({}^m\mathcal{F}(V) - \{0\})/\mathbf{R}_+$ then inherits a structure of smooth manifold diffeomorphic to a sphere. For instance, ${}^m\tilde{\mathcal{P}}^k := ({}^m\mathcal{F}^k - \{0\})/\mathbf{R}_+$ is diffeomorphic to the sphere $S^{k(m-1)-1}$.

(2.2) Suppose now that V is oriented and is a Euclidean space, namely V is endowed with a scalar product. The group $O(V)$ of isometries of V acts on ${}^k\mathcal{F}^m$ and ${}^m\tilde{\mathcal{P}}(V)$; we define the moduli spaces

$${}^m\mathcal{P}(V)_+ := SO(V) \backslash {}^m\tilde{\mathcal{P}}(V) \quad \text{and} \quad {}^m\mathcal{P}(V) := O(V) \backslash {}^m\tilde{\mathcal{P}}(V)$$

of m -polygons in V , up to similitude (where $SO(V)$ is the identity component of $O(V)$). Observe that any orientation preserving isometry $h: V \xrightarrow{\sim} \mathbf{R}^k$ produces identifications

$${}^m\mathcal{P}(V)_+ \simeq {}^m\mathcal{P}_+^k := SO_k \backslash {}^m\tilde{\mathcal{P}}^k \quad \text{and} \quad {}^m\mathcal{P}(V) \simeq {}^m\mathcal{P}^k := O_k \backslash {}^m\tilde{\mathcal{P}}^k.$$

We shall use the fact that these identifications do not depend on the choice of h and thus ${}^m\mathcal{P}(V)_+$ and ${}^m\mathcal{P}(V)$, for any Euclidean space V , are canonically identified with ${}^m\mathcal{P}_+^k$ and ${}^m\mathcal{P}^k$.

(2.3) The “degree of improperness” of polygons provides a stratification

$$\emptyset = E_1 {}^m\tilde{\mathcal{P}}(V) \subset E_2 {}^m\tilde{\mathcal{P}}(V) \subset \cdots \subset E_{m-1} {}^m\tilde{\mathcal{P}}(V) \subset E_m {}^m\tilde{\mathcal{P}}(V) = {}^m\tilde{\mathcal{P}}(V)$$

where

$$E_j {}^m\tilde{\mathcal{P}}(V) := \{\rho \in {}^m\tilde{\mathcal{P}}(V) \mid \#\{s \mid \rho(s) = 0\} \geq m - j\}.$$

The “open stratum” $E_j {}^m\tilde{\mathcal{P}}(V) - E_{j-1} {}^m\tilde{\mathcal{P}}(V)$ is a smooth submanifold of ${}^m\tilde{\mathcal{P}}(V)$ of dimension $(j-1)k-1$ if $k = \dim V$. The top open stratum ${}^m\tilde{\mathcal{P}}(V) - E_{m-1} {}^m\tilde{\mathcal{P}}(V)$, open and dense in ${}^m\tilde{\mathcal{P}}(V)$, is the space of proper polygons.

As this stratification is $O(V)$ -invariant, it projects onto stratifications $\{E_j {}^m\mathcal{P}_+^k\}$ and $\{E_j {}^m\mathcal{P}^k\}$ of the moduli spaces (using the canonical identifications of (2.2)). We shall see in §3 that the above stratifications describe the singular loci of smooth orbifold structures on the spaces ${}^m\tilde{\mathcal{P}}(V)$, ${}^m\mathcal{P}_+^k$ and ${}^m\mathcal{P}^k$.

(2.4) The map $\rho \mapsto |\rho| := \sum_{j=1}^m |\rho(j)|$ which associates to a polygon ρ its total perimeter is a norm on ${}^m\mathcal{F}(V)$. We denote by $S({}^m\mathcal{F}(V))$ the sphere of radius 2 for this norm. Each class in ${}^m\tilde{\mathcal{P}}(V)$ has a unique representative in $S({}^m\mathcal{F}(V))$ which gives a topological embedding $\iota: {}^m\tilde{\mathcal{P}}(V) \rightarrow S({}^m\mathcal{F}(V))$ whose image is $S({}^m\mathcal{F}(V))$. The image by ι of $E_{m-1} {}^m\tilde{\mathcal{P}}(V)$ is the subset of $S({}^m\mathcal{F}(V))$ where $S({}^m\mathcal{F}(V))$ fails to be a smooth submanifold of ${}^m\mathcal{F}(V)$. However, the restriction of ι to each $E_j {}^m\tilde{\mathcal{P}}(V) - E_{j-1} {}^m\tilde{\mathcal{P}}(V)$ is a smooth embedding.

The map $\tilde{\ell}: {}^m\mathcal{F}(V) \rightarrow \mathbf{R}^m$ defined by $\tilde{\ell}(\rho) := (|\rho(1)|, \dots, |\rho(m)|)$ associates to a polygon its side-lengths. We define $\ell: {}^m\tilde{\mathcal{P}}(V) \rightarrow \mathbf{R}^m$ by $\ell := \tilde{\ell} \circ \iota$. We shall also use the notation $\ell_i(\rho)$ for $|\rho(i)|$. These maps are invariant under the $O(V)$ -action and thus define maps (always called ℓ)

$$\ell: {}^m\mathcal{P}_+^k \rightarrow \mathbf{R}^m \quad \text{and} \quad \ell: {}^m\mathcal{P}^k \rightarrow \mathbf{R}^m$$

which are smooth on each open stratum.

(2.5) Let $\tau: V \rightarrow V$ be the orthogonal reflection through some hyperplane Π in V . One has the involution $\rho \mapsto \check{\rho} := \tau \circ \rho$ on ${}^m\mathcal{F}(V)$ and ${}^m\tilde{\mathcal{P}}(V)$ whose fixed-point space is naturally ${}^m\mathcal{F}(\Pi)$ and ${}^m\tilde{\mathcal{P}}(\Pi)$. If $h \in SO(V)$, one has

$$\tau \circ h = \underbrace{(\tau \circ h \circ \tau \circ h^{-1})}_{\in SO(V)} \circ h \circ \tau.$$

Hence the involution descends to an involution (still denoted $\rho \mapsto \check{\rho}$) on ${}^m\mathcal{P}_+^k$. If τ' is an orthogonal reflection with respect to another hyperplane Π' , then the formula $\tau \circ \rho' = (\tau' \circ \tau) \circ \tau \circ \rho$ shows that the induced involution on ${}^m\mathcal{P}_+^k$ does not depend on the choice of τ . The fixed point space of $\check{\cdot}$ is ${}^m\mathcal{P}^{k-1}$. Observe that $\check{\rho} = \rho$ in ${}^m\mathcal{P}^k$.

EXAMPLES

(2.6) *Polygons in the line.* The space ${}^m\tilde{\mathcal{P}}^1 = {}^m\tilde{\mathcal{P}}_+^1$ is diffeomorphic to the sphere S^{m-2} . Under this identification, the O_1 -action becomes the antipodal map and thus ${}^m\mathcal{P}^1$ is a smooth manifold diffeomorphic to $\mathbf{R}P^{m-2}$. For example, ${}^3\tilde{\mathcal{P}}^1 \simeq S^1$ and ${}^3\mathcal{P}^1 \simeq \mathbf{R}P^1$. The stratum $E_2{}^3\tilde{\mathcal{P}}^1$ consists of 3 pairs of antipodal points and thus $E_2{}^3\mathcal{P}^1$ is a set of 3 points, the three triangles with one side of length 0. This corresponds to the fact that $S({}^3\mathcal{F}^1)$ is a regular hexagon and $O_1 \backslash S({}^3\mathcal{F}^1)$ is a triangle. Actually, the map $\ell : {}^3\mathcal{P}^1 \rightarrow \mathbf{R}^3$ produces homeomorphisms

$${}^3\mathcal{P}^1 \xrightarrow[\simeq]{\ell} \{(x, y, z) \in \mathbf{R}_{\geq 0}^3 \mid x + y + z = 2 \text{ and } \pm x \pm y \pm z = 0\}.$$

(2.7) *Polygons in the plane.* Identifying \mathbf{R}^2 with \mathbf{C} , the space ${}^m\mathcal{F}^2$ is a complex vector space isomorphic to \mathbf{C}^{m-1} and the (free) SO_2 -action corresponds to the diagonal U_1 -action. As in (2.6) one establishes the diffeomorphisms

$$\begin{array}{ccc} {}^m\tilde{\mathcal{P}}^2 & \xrightarrow{\simeq} & S^{2m-3} \\ \downarrow & & \downarrow \\ {}^m\mathcal{P}_+^2 & \xrightarrow{\simeq} & \mathbf{C}P^{m-2} \end{array}$$

The above diffeomorphisms conjugate the involutions $\check{\cdot}$ with the complex conjugations of \mathbf{C}^{m-1} and $\mathbf{C}P^{m-2}$. Also, the involution $\check{\cdot}$ on ${}^m\mathcal{P}_+^2$ coincides with the residual O_1 action and therefore ${}^m\mathcal{P}^2$ is the quotient of $\mathbf{C}P^{m-2}$ by its complex conjugation.

For example, ${}^3\tilde{\mathcal{P}}^2$, the space of planar triangles, is diffeomorphic to the sphere S^3 . The singular stratum $E_2({}^3\tilde{\mathcal{P}}^1)$ is a link of three circles which are SO_2 -orbits (therefore, any two of them constitute a Hopf link). The quotient ${}^3\mathcal{P}_+^2$ is identified with $\mathbf{C}P^1$ and $E_2({}^3\tilde{\mathcal{P}}_+^1)$ is a set of three points in $\mathbf{C}P^1$.

Finally, ${}^3\mathcal{P}^2 \simeq \mathbf{C}P^1 / \{z \sim \bar{z}\}$ is homeomorphic, via the length-side map ℓ , to the solid triangle

$${}^3\mathcal{P}^2 = {}^3\mathcal{P}^3 \xrightarrow[\simeq]{\ell} \{(x_1, x_2, x_3) \in \mathbf{R}^3 \mid x_1 + x_2 + x_3 = 2 \text{ and } 0 \leq x_i \leq 1\}$$

with boundary ${}^3\mathcal{P}^1$.

3. QUATERNIONS, GRASSMANNIANS AND STRUCTURES ON THE FULL POLYGON SPACES

(3.1) Let $\mathbf{H} = \mathbf{C} \oplus \mathbf{C}j$ be the skew-field of quaternions; the space $I\mathbf{H}$ of pure imaginary quaternions is equipped with the orthonormal basis i, j and $k = ij$, giving rise to an isometry with \mathbf{R}^3 which turns the pure imaginary part of the quaternionic multiplication pq into the usual cross product $p \times q$. The space ${}^m\mathcal{F}^3$ is thus identified with ${}^m\mathcal{F}(I\mathbf{H})$ which gives rise to the canonical identifications on the various moduli spaces (see (2.2)).

Recall that the correspondence

$$\eta : u + vj \mapsto \begin{pmatrix} u & v \\ -\bar{v} & \bar{u} \end{pmatrix}$$

gives an injective \mathbf{R} -algebra homomorphism $\eta : \mathbf{H} \longrightarrow \mathcal{M}_{(2 \times 2)}(\mathbf{C})$. This enables a matrix $P \in U_2$ to act on the right or on the left on \mathbf{H} . It also identifies the group S^3 of unit quaternions with SU_2 .

(3.2) The Hopf map $\phi : \mathbf{H} \longrightarrow I\mathbf{H}$ defined by

$$\phi(q) := \bar{q} i q$$

sends the 3-sphere of radius \sqrt{r} in \mathbf{H} onto the 2-sphere of radius r in $I\mathbf{H}$. (The formulae given in the original paper by Hopf [Ho, §5] actually correspond to the map $q \mapsto \bar{q}kq$.) The equality $\phi(q) = \phi(q')$ occurs if and only if $q' = e^{i\theta} q$. The map ϕ satisfies the equivariance relation $\phi(q \cdot P) = P^{-1} \cdot \phi(q) \cdot P$. Writing $q = u + vj$ with $u, v \in \mathbf{C}$, one has

$$\phi(u + vj) = (\bar{u} - j\bar{v}) i(u + vj) = i(\bar{u} + j\bar{v})(u + vj) = i[(|u|^2 - |v|^2) + 2\bar{u}vj].$$

(3.3) Observe that if $q = s + tj$ with $s, t \in \mathbf{R}$, then $\phi(q) = iq^2$. This plane $\mathbf{R} \oplus \mathbf{R}j$ of its images is the fixed point set of the involution $a + bj \mapsto \bar{a} + \bar{b}j$ that will be used later. Its image under ϕ is $\mathbf{R}i \oplus \mathbf{R}k$.

(3.4) REMARK. $I\mathbf{H}$, with the Lie bracket $[p, q] = pq - qp = 2 \operatorname{Im}(pq)$, is the Lie algebra for the group $U_1(\mathbf{H}) \simeq SU_2 \simeq S^3$. The pairing

$(q, q') \mapsto -\operatorname{Re}(qq') = \langle q, q' \rangle$ identifies $I\mathbf{H}$ with its dual. If $\mathbf{H} \simeq \mathbf{C} \oplus \mathbf{C}$ is endowed with the standard Kähler form, then the map $\frac{1}{2}\phi$ is the moment map for the Hamiltonian action of $U_1(\mathbf{H})$ on \mathbf{H} (the factor $\frac{1}{2}$ can be checked by restricting the action to the S^1 -action on \mathbf{C}).

(3.5) Let $\mathbf{V}_2(\mathbf{C}^m)$ be the space of $(m \times 2)$ -matrices

$$(a, b) := \begin{pmatrix} a_1 & b_1 \\ \vdots & \vdots \\ a_m & b_m \end{pmatrix} \in \mathcal{M}_{m \times 2}(\mathbf{C})$$

such that $|a| = |b| = 1$ and $\langle a, b \rangle = 0$. $\mathbf{V}_2(\mathbf{C}^m)$ is the Stiefel manifold of orthonormal 2-frames in \mathbf{C}^m . The group U_m acts transitively on the left on $\mathbf{V}_2(\mathbf{C}^m)$ producing the diffeomorphism $\mathbf{V}_2(\mathbf{C}^m) = U_m/U_{m-2}$. One has the conjugation on $\mathbf{V}_2(\mathbf{C}^m)$ given by $(a, b) \mapsto (\bar{a}, \bar{b})$ with fixed-point space the Stiefel manifold $\mathbf{V}_2(\mathbf{R}^m) = O_m/O_{m-2}$ of orthonormal 2-frames in \mathbf{R}^m . Finally, the embedding $\mathbf{V}_2(\mathbf{C}^m) \subset \mathbf{H}^m$ given by $(a, b) \mapsto (\dots, a_r + b_r j, \dots)$ intertwines the conjugation on $\mathbf{V}_2(\mathbf{C}^m)$ with the involution of (2.5) on \mathbf{H}^m . One thus gets an embedding $\mathbf{V}_2(\mathbf{R}^m) \subset (\mathbf{R} \oplus \mathbf{R}j)^m$.

Using the Hopf map ϕ of (3.2), one defines the smooth map $\Phi : \mathbf{V}_2(\mathbf{C}^m) \rightarrow {}^m\mathcal{F}(I\mathbf{H}) \simeq {}^m\mathcal{F}^3$ by the formula

$$\Phi(a, b) := (\phi(a_1 + b_1 j), \phi(a_2 + b_2 j), \dots, \phi(a_m + b_m j)).$$

The fact that $\sum \phi(a_r + b_r j) = 0$ is equivalent to $\langle a, b \rangle = 0$ and $|a| = |b|$. As $|a| = |b| = 1$, the image of Φ is exactly $S({}^m\mathcal{F}^3)$. By composing with the projection ${}^m\mathcal{F}^3 - \{0\} \rightarrow {}^m\tilde{\mathcal{P}}^3$, one gets a surjective smooth map $\Phi : \mathbf{V}_2(\mathbf{C}^m) \rightarrow {}^m\tilde{\mathcal{P}}^3$. One checks that $\Phi(a, b) = \Phi(a', b')$ if and only if (a, b) and (a', b') are in the same orbit under the action of the maximal torus U_1^m of diagonal matrices in U_m . This action is free when none of the (a_i, b_i) 's vanishes, namely if and only if $\Phi(a, b)$ is a proper polygon. As $\Phi(\bar{a}, \bar{b}) = \Phi(a, b)^\vee$, the restriction of Φ to the fixed points gives a smooth map $\Phi_{\mathbf{R}} : \mathbf{V}_2(\mathbf{R}^m) \rightarrow {}^m\tilde{\mathcal{P}}(\mathbf{R}i \oplus \mathbf{R}k) \simeq {}^m\tilde{\mathcal{P}}^2$ with analogous properties. We have thus proved

THEOREM 3.6. *a) The smooth map $\Phi : \mathbf{V}_2(\mathbf{C}^m) \rightarrow {}^m\tilde{\mathcal{P}}^3$ induces a homeomorphism $\hat{\Phi} : U_1^m \backslash \mathbf{V}_2(\mathbf{C}^m) \xrightarrow{\simeq} {}^m\tilde{\mathcal{P}}^3$ such that $\hat{\Phi}(\bar{a}, \bar{b}) = \Phi(a, b)^\vee$. The restriction of Φ above the space of proper polygons is a smooth principal U_1^m -bundle.*

b) The smooth map $\Phi_{\mathbf{R}} : \mathbf{V}_2(\mathbf{R}^m) \rightarrow {}^m\tilde{\mathcal{P}}^2$ induces a homeomorphism $\hat{\Phi}_{\mathbf{R}} : O_1^m \backslash \mathbf{V}_2(\mathbf{R}^m) \xrightarrow{\simeq} {}^m\tilde{\mathcal{P}}^2$. The restriction of $\Phi_{\mathbf{R}}$ above the space of proper planar polygons is a principal O_1^m -covering.

COROLLARY 3.7. ${}^m\tilde{\mathcal{P}}^3 \simeq U_1^m \backslash U_m / U_{m-2}$ and ${}^m\tilde{\mathcal{P}}^2 \simeq O_1^m \backslash O_m / O_{m-2}$.

(3.8) Let $\mathbf{G}_2(\mathbf{C}^m)$ be the Grassmann manifold of 2-planes in \mathbf{C}^m . The map $\mathbf{V}_2(\mathbf{C}^m) \rightarrow \mathbf{G}_2(\mathbf{C}^m)$ which associates to (a, b) the plane generated by a and b is the projection $\mathbf{V}_2(\mathbf{C}^m) \rightarrow \mathbf{V}_2(\mathbf{C}^m)/U_2$ (a principal U_2 bundle), for the natural right action of U_2 on $\mathbf{V}_2(\mathbf{C}^m) \subset \mathcal{M}_{m \times 2}(\mathbf{C})$. This projection is U_m -equivariant, equivalent to the projection $U_m/U_{m-2} \rightarrow U_m/U_2 \times U_{m-2}$.

The map $\Phi : \mathbf{V}_2(\mathbf{C}^m) \rightarrow {}^m\tilde{\mathcal{P}}^3$ satisfies

$$\Phi((a, b)P) = P^{-1} \Phi(a, b)P \quad \text{for } (a, b) \in \mathbf{V}_2(\mathbf{C}^m), P \in U_2.$$

The conjugation by P being an element of $SO(I\mathbf{H})$, one thus gets a map (still called Φ) from $\mathbf{G}_2(\mathbf{C}^m)$ onto ${}^m\mathcal{P}_+^3$. The space ${}^m\mathcal{P}_+^3$ has a smooth structure on the open-dense subset of non-lined polygons (which is where the SO_3 -action was free) and, above this open-dense subset, the new map Φ is smooth. The map Φ intertwines the involutions and so restricts to a map $\Phi_{\mathbf{R}} : \mathbf{G}_2(\mathbf{R}^m) \rightarrow {}^m\mathcal{P}^2$, where $\mathbf{G}_2(\mathbf{R}^m)$ is the Grassmannian of 2-planes in \mathbf{R}^m . In this case, an intermediate object is the Grassmannian $\tilde{\mathbf{G}}_2(\mathbf{R}^m) = SO_m/SO_2 \times SO_{m-2}$ of oriented 2-planes in \mathbf{R}^m with the smooth map $\Phi_{\mathbf{R}} \tilde{\mathbf{G}}_2(\mathbf{R}^m) \rightarrow {}^m\mathcal{P}_+^2 \simeq \mathbf{C}P^{m-2}$. The action of U_1^m on $\mathbf{V}_2(\mathbf{C}^m)$ descends to an action on $\mathbf{G}_2(\mathbf{C}^m)$ which is no longer effective: its kernel is the diagonal subgroup Δ of U_1^m , the center of U_m , isomorphic to U_1 . The same holds true in the real case, replacing U_1 by O_1 (the diagonal subgroup of O_1^m is also denoted by Δ).

Using Theorem 3.6, the reader will easily prove the following

THEOREM 3.9. *a) The map $\Phi : \mathbf{G}_2(\mathbf{C}^m) \rightarrow {}^m\mathcal{P}^3$ induces a homeomorphism $\hat{\Phi} : U_1^m \backslash \mathbf{G}_2(\mathbf{C}^m) \xrightarrow{\simeq} {}^m\mathcal{P}^3$ such that $\hat{\Phi}(\bar{a}, \bar{b}) = \Phi(a, b)^\vee$. The restriction of $\hat{\Phi}$ above the space of proper non-lined polygons is a smooth principal (U_1^m/Δ) -bundle.*

b) The smooth map $\Phi_{\mathbf{R}} : \tilde{\mathbf{G}}_2(\mathbf{R}^m) \rightarrow {}^m\mathcal{P}_+^2$ induces a homeomorphism $\hat{\Phi}_{\mathbf{R}} : O_1^m \backslash \tilde{\mathbf{G}}_2(\mathbf{R}^m) \xrightarrow{\simeq} {}^m\mathcal{P}_+^2$. It is a smooth branched covering and, restricted above the space of proper polygons, a principal (O_1^m/Δ) -covering.

c) The map $\Phi_{\mathbf{R}} : \mathbf{G}_2(\mathbf{R}^m) \rightarrow {}^m\mathcal{P}^2$ induces a homeomorphism $\hat{\Phi}_{\mathbf{R}} : O_1^m \backslash \mathbf{G}_2(\mathbf{R}^m) \xrightarrow{\simeq} {}^m\mathcal{P}^2$. The restriction of $\hat{\Phi}$ above the space of proper non-lined polygons is a principal (O_1^m/Δ) -covering.

COROLLARY 3.10. *One has homeomorphisms between the polygon spaces and the double cosets*

- a) ${}^m\mathcal{P}^3 \simeq U_1^m \backslash U_m / (U_2 \times U_{m-2})$
- b) ${}^m\mathcal{P}_+^2 \simeq S(O_1^m) \backslash SO_m / (SO_2 \times SO_{m-2})$.
- c) ${}^m\mathcal{P}^2 \simeq O_1^m \backslash O_m / (O_2 \times O_{m-2})$.

(3.11) *Example.* As in (2.7) the example of planar triangles ($m = 3$ and $k = 2$) is interesting. The Stiefel manifold $\mathbf{V}_2(\mathbf{R}^3)$ is diffeomorphic to the unit tangent bundle to S^2 , in turn diffeomorphic to SO_3 . The oriented Grassmannian $\tilde{\mathbf{G}}_2(\mathbf{R}^3)$ can be identified with S^2 by associating to an oriented plane its unit normal vector. The smooth map

$$\Phi_{\mathbf{R}} : S^2 \simeq \tilde{\mathbf{G}}_2(\mathbf{R}^3) \longrightarrow {}^3\mathcal{P}_+^2 \simeq S^2$$

is of degree 4, branched over the 3 points. This map can be visualized as follows: tessellate \mathbf{R}^2 with equilateral triangles. Divide \mathbf{R}^2 by the subgroup of isometries which preserve the tessellation and the orientation (it thus preserves a checkerboard coloring of the triangle tessellation). This quotient is a well known orbifold structure on S^2 with three branched points. The projection $\mathbf{R}^2 \longrightarrow S^2$ factors through an octahedron with a chess-board coloring of its faces. The residual map from this octahedron to S^2 is our map $\Phi_{\mathbf{R}}$.

Take the pullback by $\Phi_{\mathbf{R}}$ of the Hopf bundle $S^3 \longrightarrow S^2$. One gets a map of degree 4 from some lens space L onto S^3 , with branched locus the link formed by three SO_2 -orbits. The lens space will be doubly covered by SO_3 . We thus get the map

$$\tilde{\Phi} : SO_3 \simeq \mathbf{V}_2(\mathbf{R}^3) \longrightarrow {}^3\tilde{\mathcal{P}}^2 \simeq S^3$$

of degree 8. Finally, one has $\mathbf{G}_2(\mathbf{R}^3) \simeq \mathbf{RP}^2$ and $\Phi_{\mathbf{R}}$ is the quotient of \mathbf{RP}^2 by the action of O_1^3 on each homogeneous coordinate. This quotient is a 2-simplex and one sees again that ${}^3\mathcal{P}^2$ is a solid triangle.

(3.12) *Orbifold structures.* The maps $\hat{\Phi}_{\mathbf{R}}$ and $\Phi_{\mathbf{R}}$ provide, for the spaces ${}^2\tilde{\mathcal{P}}^2 \simeq S^{2m-3}$ and ${}^m\mathcal{P}_+^2 \simeq \mathbf{CP}^{m-2}$, a smooth orbifold structure. Each point has a neighbourhood homeomorphic to an open set of the quotient of $(\mathbf{R}^2)^s$ by a subgroup of O_1^s , where O_1 acts on each \mathbf{R}^2 via the antipodal map. Observe that the map $\Phi_{\mathbf{R}}$ is a “small cover” in the sense of [DJ]. The branched loci are $E_{m-1} {}^m\tilde{\mathcal{P}}^2$ and $E_{m-1} {}^m\mathcal{P}_+^2$ respectively. As for ${}^m\mathcal{P}^2$ we have to add the branched locus ${}^m\mathcal{P}^1$. The generic points of ${}^m\mathcal{P}^1$ have a neighbourhood modelled on the quotient of \mathbf{C}^{m-2} by complex conjugation.

Analogously, the map $\Phi: \mathbf{G}_2(\mathbf{C}^m) \longrightarrow {}^m\mathcal{P}^3$ gives rise, for the space ${}^m\tilde{\mathcal{P}}^3$, to a smooth *complex orbifold structure*. By that we mean a space locally modelled on the quotient of \mathbf{C}^s by a subgroup of U_1^s . We define the space $\mathcal{C}^\infty({}^m\mathcal{P}^3)$ of *smooth maps* from ${}^m\mathcal{P}^3$ to the reals as the subspace of $\mathcal{C}^\infty(\mathbf{G}_2(\mathbf{C}^m))$ which is invariant by the action of U_1^m .

(3.13) *Riemannian and Poisson structures.* Let $\mathcal{H}(m)$ be the space of Hermitian $(m \times m)$ -matrices, identified with \mathbf{u}_m^* via the pairing

$$\mathcal{H}(m) \times \mathbf{u}_m \longrightarrow \mathbf{R} \quad (H, X) \mapsto \frac{i}{2} \operatorname{tr}(HX).$$

This identification turns the co-adjoint action of U_m into the conjugation action on $\mathcal{H}(m)$. Consider the map $\tilde{\Psi}: \mathcal{M}_{m \times 2}(\mathbf{C}) \longrightarrow \mathcal{H}(m)$ given by $\tilde{\Psi}(a, b) := (a, b) \cdot (a, b)^*$. One has $\tilde{\Psi}(Q \cdot (a, b) \cdot P) = Q \cdot \tilde{\Psi}((a, b)) \cdot Q^*$ for $P \in U_2$ and $Q \in U_m$ and thus $\mathcal{C} := \tilde{\Psi}(\mathbf{V}_2(\mathbf{C}^m))$ is the U_m -orbit through $\operatorname{diag}(1, 1, 0, \dots, 0)$. This proves that $\tilde{\Psi}$ descends to a diffeomorphism $\Psi: \mathbf{G}_2(\mathbf{C}^m) \xrightarrow{\cong} \mathcal{C}$.

The complex vector space $\mathcal{M}_{m \times 2}(\mathbf{C})$ is endowed with its classical Hermitian structure $\langle A, B \rangle := \operatorname{tr}(AB^*)$, with associated symplectic form $\omega(\cdot, \cdot) = -\operatorname{Im} \langle \cdot, \cdot \rangle$. The map $\tilde{\Psi}$ above and the map $\tilde{\Phi}: \mathcal{M}_{m \times 2}(\mathbf{C}) \longrightarrow \mathcal{H}_0(2)$ given by

$$\tilde{\Phi}(a, b) := (a, b)^* \cdot (a, b) - \begin{pmatrix} 1 & 0 \\ 0 & 1 \end{pmatrix}$$

are moment maps for the Hamiltonian actions of U_m and U_2 respectively. One has $\mathbf{V}_2(\mathbf{C}^m) = \tilde{\Phi}^{-1}(0)$ and thus $\mathbf{G}_2(\mathbf{C}^m)$ occurs as symplectic reduction of the Hermitian vector space $\mathcal{M}_{m \times 2}(\mathbf{C})$ and thereby inherits a U_m -invariant Kähler structure, using, for instance [Ki], §1.7. (Strictly speaking, one deals in [Ki] with compact Kähler manifolds; to fulfill this condition, one can first divide $\mathcal{M}_{m \times 2}(\mathbf{C}) - \{0\}$ by the diagonal action of \mathbf{C}^* to put oneself into a complex projective space.) The residual map $\Psi: \mathbf{G}_2(\mathbf{C}^m) \xrightarrow{\cong} \mathcal{C} \subset \mathcal{H}(m)$ is a moment map for the action of U_m on $\mathbf{G}_2(\mathbf{C}^m)$.

Being thus a Kähler manifold, $\mathbf{G}_2(\mathbf{C}^m)$ is a Riemannian Poisson manifold. This structure descends to the complex orbifold ${}^m\mathcal{P}^3$: the algebra $\mathcal{C}^\infty({}^m\mathcal{P}^3)$ admits a unique Lie bracket so that the projection $\mathbf{G}_2(\mathbf{C}^m) \longrightarrow {}^m\mathcal{P}^3$ is a Poisson map.

(3.14) It is possible to endow with a Poisson structure the space ${}^m\mathcal{P}\mathcal{P}_+^3$ of configurations of *all* m -gons in \mathbf{R}^3 , without fixing the perimeter to 2. It suffices in the above construction, to replace the U_2 -reduction $\mathbf{G}_2(\mathbf{C}^m) = \tilde{\Phi}^{-1}(0)/U_2$ by the SU_2 -reduction $\tilde{\mathbf{G}}_2(\mathbf{C}^m) := \tilde{\Phi}^{-1}(0)/SU_2$. The latter is a non-compact space, the total space of the determinant bundle over $\mathbf{G}_2(\mathbf{C}^m)$ with the zero

section collapsed. The trace function on $\mathcal{M}_{m \times 2}(\mathbf{C})$ descends to $\tilde{\mathbf{G}}_2(\mathbf{C}^m)$ and to the Casimir function “perimeter” on ${}^m\mathcal{P}\mathcal{P}_+^3$.

4. POLYGONS WITH GIVEN SIDES – KÄHLER STRUCTURES

We now use the map $\ell : {}^m\tilde{\mathcal{P}}^k, {}^m\mathcal{P}_+^k, {}^m\mathcal{P}^k \rightarrow \mathbf{R}^m$ defined in (2.4). Recall that $\ell(\rho)$, for $\rho \in {}^m\tilde{\mathcal{P}}^k$, is the length of the successive sides of a representative of r with total perimeter 2.

For $\alpha = (\alpha_1, \dots, \alpha_m) \in \mathbf{R}_{\geq 0}^m$ with $\sum_{i=1}^m \alpha_i = 2$, we define

$${}^m\tilde{\mathcal{P}}^k(\alpha) :=: \tilde{\mathcal{P}}^k(\alpha) := \{\rho \in {}^m\tilde{\mathcal{P}}^k \mid \ell(\rho) = \alpha\} \subset {}^m\tilde{\mathcal{P}}^k.$$

The space $\tilde{\mathcal{P}}^k(\alpha)$ is invariant under the action of O_k . We define the moduli spaces

$$\mathcal{P}_+^k(\alpha) := SO_k \backslash \tilde{\mathcal{P}}^k(\alpha) = \ell^{-1}(\alpha) \subset {}^m\mathcal{P}_+^k$$

and

$$\mathcal{P}^k(\alpha) := O_k \backslash \tilde{\mathcal{P}}^k(\alpha) = \ell^{-1}(\alpha) \subset {}^m\mathcal{P}^k.$$

The space $\tilde{\mathcal{P}}^1(\alpha)$ consists of a finite number of points and is generically empty. We call α *generic* if $\tilde{\mathcal{P}}^1(\alpha) = \emptyset$.

THEOREM 4.1. *The map $\mu := \ell \circ \hat{\Phi} : \mathbf{G}_2(\mathbf{C}^m) \rightarrow \mathbf{R}^m$ is a moment map for the action of U_1^m on $\mathbf{G}_2(\mathbf{C}^m)$.*

Proof. As seen in (3.13), the moment map $\Psi : \mathbf{G}_2(\mathbf{C}^m) \rightarrow \mathcal{H}(m)$ for the U_m -action on $\mathbf{G}_2(\mathbf{C}^m)$ is induced from $\tilde{\Psi} : \mathcal{M}_{m \times 2}(\mathbf{C}) \rightarrow \mathcal{H}(m)$ given by $\tilde{\Psi}(a, b) := (a, b) \cdot (a, b)^*$. A moment map μ for the action of U_1^m is obtained by composing Ψ with the projection $\mathcal{H}(m) \rightarrow \mathbf{R}^m$ associating to a matrix its diagonal entries. So, if $\Pi \in \mathbf{G}_2(\mathbf{C}^m)$ is generated by a and b with $(a, b) \in \mathbf{V}_2(\mathbf{C}^m)$, one has

$$\mu(\Pi) = (|a_1|^2 + |b_1|^2, \dots, |a_m|^2 + |b_m|^2) = \ell \circ \hat{\Phi}(a, b). \quad \square$$

A now classic theorem of Atiyah and Guillemin-Sternberg [Au, §III.4.2] asserts that the image of a moment map for a torus action is a convex polytope (the *moment polytope*). The restriction of the moment map to the fixed point set of an anti-symplectic involution has the same image [Du]. In our case, one gets these facts directly :

COROLLARY 4.2. *The moment map $\mu: \mathbf{G}_2(\mathbf{C}^m) \longrightarrow \mathbf{R}^m$ satisfies $\mu(\mathbf{G}_2(\mathbf{C}^m)) = \mu(\mathbf{G}_2(\mathbf{R}^m)) = \Xi_m$, where Ξ_m is the hypersimplex*

$$\Xi_m := \{(x_1, \dots, x_m) \in \mathbf{R}^m \mid 0 \leq x_i \leq 1 \text{ and } \sum_{i=1}^m x_i = 2\}.$$

Proof. One has $\text{Image}(\mu) = \text{Image}(\ell)$. Further it is manifest that $\text{Image}(\ell) \subset \Xi_m$. A proof that $\text{Image}(\ell) = \Xi_m$ is actually provided in [KM1], Lemma 1, or [Ha]. We give here however another argument, for the pleasure of constructing a continuous section $\sigma: \Xi_m \longrightarrow {}^m\mathcal{P}^2$ of ℓ . If $m = 3$, we have already mentioned in (2.7) that ${}^3\mathcal{P}^2$ is homeomorphic to Ξ_3 via the map ℓ . Let $\alpha \in \Xi_m$. Define $\beta_i := \sum_{j=1}^i \alpha_j$ and

$$r(\alpha) := \min\{i \mid \beta_i \leq 1 \text{ and } \beta_{i+1} \geq 1\}.$$

The numbers $\beta_r, \alpha_r, 2 - \beta_{r+1}$ form a triple of Ξ_3 and are then the lengths of a unique triangle $\tau(\alpha) \in {}^3\mathcal{P}^2$, which can be subdivided in the obvious way to define the element $\sigma(\alpha) \in {}^m\mathcal{P}^2(\alpha)$ (see Figure 1).

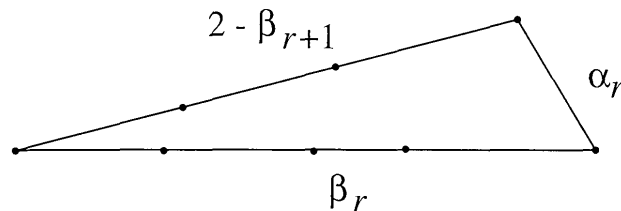

FIGURE 1: $\tau(\alpha)$

The continuity of σ comes from the fact that if the map r is discontinuous at some α , the triangle $\tau(\alpha)$ is then lined. \square

REMARKS. 1) Corollary 4.2 is also a consequence of our stronger result (5.4).

2) The word “hypersimplex” is introduced in [GM]. Observe that H is obtained by taking the convex hull of the middle point of each edge of a standard $(m - 1)$ -simplex.

We also obtain the critical values of μ (compare [Ha]):

PROPOSITION 4.3. *The set of critical values of μ on $\mathbf{G}_2(\mathbf{C}^m) \rightarrow \Xi_m$ or $\mathbf{G}_2(\mathbf{R}^m) \rightarrow \Xi_m$ consists of those points $(x_1, \dots, x_m) \in \Xi_m$ satisfying one of the following conditions:*

- a) *one x_i vanishes;*
- b) *one x_i is equal to 1;*
- c) *there exist $\varepsilon_i = \pm 1$ such that $\sum_{i=1}^m \varepsilon_i x_i = 0$, with at least two ε_i 's of each sign.*

REMARK. Points satisfying a) and b) constitute the boundary of Ξ_m . Points satisfying c) are "inner walls". Points satisfying a) correspond to non-proper polygons. Those satisfying b) or c) are non-generic α 's (Condition b) implies that there exist $\varepsilon_i = \pm 1$ such that $\sum_{i=1}^m \varepsilon_i x_i = 0$ with all but one ε_i of the same sign.)

Proof. The critical points of the moment map μ are the points of $\mathbf{G}_2(\mathbf{C}^m)$ for which the U_1^m -action has a stabilizer of dimension bigger than 1. They are the images of those $(2 \times m)$ -matrices in $\mathbf{V}_2(\mathbf{C}^m)$ for which the $(U_1^m \times_{U_1} U_2)$ -action has a non-discrete stabilizer. There are such points whose stabilizer is contained in $U_1^m \times \{1\}$; they are the matrix with one row vanishing and their values under μ are the points of Ξ_m satisfying a). The other points give rise to points in ${}^m\tilde{\mathcal{P}}^3 = U_1^m/\mathbf{V}_2(\mathbf{C}^m)$ so that the action of $U_2/\{\text{center of } U_2\} \simeq SO_3$ has non discrete stabilizer. Those points are the lined configurations ${}^m\tilde{\mathcal{P}}^1$. Their values in Ξ_m are the non generic α 's, which are the points in Ξ_m satisfying b) or c). \square

We have proven most of the main result of this section: for generic and proper α , the space $\mathcal{P}^3(\alpha)$ is a Kähler sub-quotient of $\mathbf{G}_2(\mathbf{C}^m)$.

THEOREM 4.4. *For $\alpha \in \text{int } \Xi_m$ generic, $\mathcal{P}_+^3(\alpha)$ is a Kähler manifold isomorphic to the Kähler reduction $U_1^m \setminus \mu^{-1}(\alpha)$. The involution \smile is antiholomorphic and $\mathcal{P}^2(\alpha)$ can be seen as the real part of $\mathcal{P}_+^3(\alpha)$.*

Proof. By 4.1, one has $\mathcal{P}^3(\alpha) = \ell^{-1}(\alpha) = U_1^m \setminus \mu^{-1}(\alpha)$ and we have seen in 3.9 that $\widehat{\Phi}(\bar{a}, \bar{b}) = \Phi(a, b)^\smile$. \square

We shall now compare the Kähler structure obtained on $\mathcal{P}_+^3(\alpha)$ from the Grassmannian to that introduced by Klyachko [Kl] or Kapovich-Millson ([KM2], §3). Using the standard cross product \times and scalar product $\langle \cdot, \cdot \rangle$ on \mathbf{R}^3 , these authors put on the sphere S_r^2 of radius r the complex structure \tilde{J}

defined by

$$\tilde{J}v := \frac{1}{r} x \times v \quad (v \in T_x S_r^2)$$

and the Kähler metric

$$\tilde{h}(u, v) := \frac{1}{r} \langle u, v \rangle - \frac{i}{r^2} \langle x, u \times v \rangle \quad (u, v \in T_x S_r^2)$$

with associated symplectic form $\tilde{\omega}(u, v) := \langle \frac{x}{r^2} u \times v \rangle$. Let $W(\alpha) := \prod_{i=1}^m S_{\alpha_i}^2$. The map $\beta : W_\alpha \rightarrow \mathbf{R}^3$ defined by $\beta(z_1, \dots, z_m) := \sum_{i=1}^m z_i$ is the moment map for the diagonal action of SO_3 on W_α . The space $\mathcal{P}_+^3(\alpha)$ thus occurs as the symplectic reduction $SO_3 \backslash \beta^{-1}(0)$.

PROPOSITION 4.5. *The complex structure J and Kähler metric h of 4.4 compare with those \tilde{J} and \tilde{h} of Kapovich-Millson in the following way:*

$$\tilde{J} = J \quad \text{and} \quad \tilde{h}(u, v) = 4h(u, v).$$

Proof. Starting from the Hermitian vector space $\mathcal{M} = \mathcal{M}_{m \times 2}(\mathbf{C})$ one sees that $\mathcal{P}^3(\alpha)$ is obtained by two successive symplectic reductions

$$\mathbf{G}_2(\mathbf{C}^m) = \tilde{\Phi}^{-1}(0)/U_2 \quad \text{and} \quad \mathcal{P}^3(\alpha) = U_1^m \backslash \mu^{-1}(\alpha)$$

(we use the notation of §3). One can perform the reductions in the reverse order. We first get

$$U_1^m \backslash \tilde{\Psi}^{-1}(\alpha) = \prod_{i=1}^m \mathbf{C}P_{\alpha_i}^1$$

where $\mathbf{C}P_r^1$ is the quotient of the 3-dimensional sphere

$$\{(u, v) \in \mathbf{C}^2 \mid |u|^2 + |v|^2 = r\}$$

by the diagonal action of U_1 . The moment map $\tilde{\Phi} : \mathcal{M} \rightarrow \mathcal{H}(2)$ gives a moment map (still called $\tilde{\Phi}$) from the product of projective spaces into $\mathcal{H}_0(2)$. One has a commutative diagram

$$\begin{array}{ccc} \prod_{i=1}^m \mathbf{C}P_{\alpha_i}^1 & \xrightarrow[\simeq]{\Pi^\phi} & \prod_{i=1}^m S_{\alpha_i}^2 \\ \tilde{\Phi} \downarrow & & \downarrow \beta \\ \mathcal{H}_0(2) & \xrightarrow[\simeq]{\psi} & \mathbf{R}^3 \end{array}$$

where $\psi : \mathcal{H}_0(2) \rightarrow \mathbf{R}^3 \simeq \mathbf{R} \times \mathbf{C}$ sends the matrix $\begin{pmatrix} u & z \\ \bar{z} & -u \end{pmatrix}$ to (u, z) .

To prove Proposition 4.5, it is enough to establish that for all $a \in \mathbf{C}P_r^1$, the tangent map $T_a\phi : T_a\mathbf{C}P_r^1 \longrightarrow T_{\phi(a)}S_r^2$ satisfies

$$T_a\phi(Jv) = \tilde{J}T_a\phi(v) \quad \text{and} \quad \tilde{\omega}(T_a\phi(v), T_a\phi(Jv)) = 4\omega(v, Jv).$$

By U_2 -equivariance, we can restrict ourselves to $a = [\sqrt{r}, 0]$. The tangent space $T_a\mathbf{C}P_r^1$ is identified with $\{0\} \times \mathbf{C}$ and one can take $v = (0, 1)$ and $Jv = (0, i)$. One has $\phi(a) = (r, 0, 0)$,

$$T_a\phi(v) = (0, 2\sqrt{r}, 0), \quad T_a\phi(Jv) = (0, 0, 2\sqrt{r}) = \tilde{J}T_a\phi(v)$$

and $\tilde{\omega}(T_a\phi(v), T_a\phi(Jv)) = 4$, while $\omega(v, Jv) = 1$. \square

REMARKS

(4.6) The results of this section show that the spaces $\mathcal{P}_+(\alpha)$ for generic α are the symplectic leaves of the Poisson structure on the regular part of ${}^m\mathcal{P}_+^3$, or ${}^m\mathcal{P}\mathcal{P}_+^3$ given in (3.13) and (3.14).

(4.7) If one works in the pure quaternions $I\mathbf{H}$, the complex structure \tilde{J} on S_r^2 becomes

$$\tilde{J}(v) = \frac{qv}{|q|}, \quad (v \in T_qS_r^2 = I\mathbf{H}).$$

The sphere S_r^2 is a co-adjoint orbit of $U_1(\mathbf{H})$ and the Hermitian form $\tilde{\omega}$ is the Kirillov–Kostant form (see [Gu, Theorem 1.1]).

(4.8) The isomorphism between the symplectic reductions of the Grassmannian $\mathbf{G}_2(\mathbf{C}^m)$ and the product of $\mathbf{C}P^1$'s that underlies our results 3.9, 4.4 and the proof of 4.5 is a symplectic version of the Gel'fand-MacPherson correspondence ([GM] and [GGMS]). The fact that this isomorphism comes from two reductions of \mathcal{M} is the philosophy of “dual pairs” (see [Mo] and the references therein).

5. THE GEL'FAND-CETLIN ACTION

On ${}^m\mathcal{F}^k$ we have so far defined the length functions $\tilde{\ell}$ measuring the distances between successive vertices. We now introduce $\tilde{d} : {}^m\mathcal{F}^k \rightarrow \mathbf{R}^m$, $\tilde{d}(\rho) = (|\rho(1)|, |\rho(1) + \rho(2)|, \dots, |\sum_{i=1}^m \rho(i)|)$, the lengths of the diagonals connecting the vertices to the origin. (Only $m - 3$ of these functions are new, as $\tilde{d}(\rho)_1 = \tilde{\ell}(\rho)_1$, $\tilde{d}(\rho)_{m-1} = \tilde{\ell}(\rho)_m$, and $\tilde{d}(\rho)_m = 0$. Hereafter we write only ℓ_i, d_i and the ρ is to be understood.)

As with $\tilde{\ell}$, the function \tilde{d} descends to continuous but only generically smooth functions d on ${}^m\tilde{\mathcal{P}}^k$, ${}^m\mathcal{P}_+^k$ and ${}^m\mathcal{P}^k$. It is smooth where no d_i vanishes, that is to say the polygon does not return to the origin prematurely. We call such a polygon P *prodigal* and call $(\ell(P), d(P))$ a *prodigal value*. The set of prodigal polygons is open dense in ${}^m\mathcal{P}_+^k$ with complement of codimension k .

For $k = 3$, there is in [KM2] (see also [K1], §2.1) introduced an action of a torus T^{m-3} on prodigal polygons; the i th circle acts by rotating the section of the polygon formed by the first i edges about the i th diagonal. (When that diagonal is length zero, there is no well-defined axis about which to rotate, and indeed the action cannot be extended continuously over this subset.) This action plainly preserves the level sets of the functions d , but more is true:

THEOREM 5.1 (KM2). *On the subspace of prodigal polygons of $\mathcal{P}_+^3(\alpha)$, the function d is a moment map for these “bending flows”.*

One important consequence of this is that the torus action also preserves the symplectic structure. It does not, seemingly, preserve the Riemannian metric nor the complex structure (the codimension of the singular set is not even; see also §6).

These functions ℓ, d lifted to $\mathbf{V}_2(\mathbf{C}^m)$ have simple matrix-theoretic interpretations. For $(a, b) \in \mathbf{V}_2(\mathbf{C}^m)$, $i = 1, \dots, m$, introduce the truncated matrices

$$M_i = \begin{pmatrix} a_1 & b_1 \\ \vdots & \vdots \\ a_i & b_i \end{pmatrix}, \text{ the first } i \text{ rows of } (a, b). \text{ Then the } 2 \times 2 \text{ matrix}$$

$$M_i^* M_i = \sum_{j=1}^i \begin{pmatrix} |a_j|^2 & \bar{a}_j b_j \\ a_j \bar{b}_j & |b_j|^2 \end{pmatrix}$$

has the eigenvalues

$$\frac{1}{2} \left(\sum_{j=1}^i (|a_j|^2 + |b_j|^2) \pm \sqrt{\left(\sum_{j=1}^i (|a_j|^2 - |b_j|^2) \right)^2 + 4 \left| \sum_{j=1}^i a_j \bar{b}_j \right|^2} \right).$$

These are calculable from ℓ and d , since

$$\ell(\Phi(a, b)) = \ell(\dots, \phi(a_i, b_i), \dots) = (\dots, |a_i|^2 + |b_i|^2, \dots)$$

and

$$\begin{aligned}
 d(\Phi(a, b)) &= (\dots, |\sum_{j=1}^i \phi(a_j, b_j)|, \dots) \\
 &= (\dots, \sqrt{\left(\sum_{j=1}^i (|a_j|^2 - |b_j|^2)\right)^2 + 4\left|\sum_{j=1}^i a_j \bar{b}_j\right|^2}, \dots)
 \end{aligned}$$

So $\sum_{j=1}^i \ell_j$ is the sum of the two eigenvalues of $M_i^* M_i$, whereas d_i is the difference. (Note that $\ell_1 = d_1$ as promised; $M_1^* M_1$'s lesser eigenvalue is 0.)

This (2×2) -matrix $M_i^* M_i$ has the same nonzero eigenvalues as the $i \times i$ matrix $M_i M_i^*$. The latter matrix is more relevant in that it is the upper left $i \times i$ submatrix of the $m \times m$ matrix $(a, b)(a, b)^*$ introduced in section (3.11).

This family of Hamiltonians — the eigenvalues of the upper left submatrices — has been studied already in [Th] and is called the classical Gel'fand-Cetlin system (our main reference is [GS1]). The linear relations established above between them and d, ℓ are summed up in the following

THEOREM 5.2. *The bending flows on ${}^m \mathcal{P}_+^3(\alpha)$ are the residual torus action from the Gel'fand-Cetlin system on the Grassmannian $\mathbf{G}_2(\mathbf{C}^m)$.*

The Gel'fand-Cetlin action on the flag manifold has always been rather mysterious (at least to us); it is pleasant that in this case it has a natural geometric interpretation.

The Gel'fand-Cetlin functions $\{e_{ij}\}_{j \leq i}$ (the j th eigenvalue of the upper left $i \times i$ submatrix) satisfy some linear inequalities that can be established using the minimax description of eigenvalues [Fr, p. 149]:

$$e_{i,j} \leq e_{i-1,j+1} \leq e_{i,j+1}.$$

For the polygon space functions l, d most of these say $0 \leq 0$; for each $i = 0, \dots, n - 1$ the nontrivial inequalities are

$$0 \leq -d_i + \sum_{\iota=1}^i \ell_\iota \leq -d_{i+1} + \sum_{\iota=1}^{i+1} \ell_\iota \leq d_i + \sum_{\iota=1}^i \ell_\iota \leq d_{i+1} + \sum_{\iota=1}^{i+1} \ell_\iota.$$

But these are transparent in our situation, as they are just the triangle inequalities!

$$\begin{aligned}
 (1) \quad & \ell_{i+1} \leq d_i + d_{i+1} \\
 & d_i \leq \ell_{i+1} + d_{i+1} \\
 & d_{i+1} \leq \ell_{i+1} + d_i
 \end{aligned}$$

(The first one, $d_i \leq \sum_{\nu=1}^i \ell_\nu$, can be proved inductively from the others starting from $d_0 = 0$.)

In [GS1] it is left as an exercise to show that (1) are the *only* inequalities satisfied; equivalently, that every point in the convex polytope $\Gamma_m \subset \mathbf{R}^m \times \mathbf{R}^m$ defined by them (and $d_0 = d_m = 0$ and $\sum_i \ell_i = 2$) is realized by some Hermitian matrix. We show this directly:

THEOREM 5.3. *The image of ${}^m\mathcal{P}^{k \geq 2}$ under the map (ℓ, d) is the whole polytope Γ_m .*

Proof. We construct the polygons directly, vertex by vertex — really establishing that each space ${}^m\tilde{\mathcal{P}}^k(\alpha, \delta)$ is nonempty (and so its quotient by $SO(k)$ is as well). We must place each new vertex on the intersection of two S^{k-1} 's, one of radius d_{i+1} from the origin, the other of radius ℓ_{i+1} from the previous vertex. The inequalities $\ell_{i+1} \leq d_i + d_{i+1}$ and $d_{i+1} \leq \ell_{i+1} + d_i$ rule out one S^{k-1} containing the other; the third inequality $d_i \leq \ell_{i+1} + d_{i+1}$ rules out their being separated balls. So they intersect in an S^{k-2} , a point or the whole S^{k-1} , anywhere on which we may place the new vertex. \square

(5.4) REMARKS

1) While the map ℓ is equivariant with respect to the usual action of S_m on \mathbf{R}^m , the map d can only be made equivariant under the involution $[i \leftrightarrow (n - i)]$, and the polytope Γ_m is correspondingly less symmetric than the hypersimplex Ξ_m .

2) That the image of (ℓ, d) is the same when restricted to planar polygons has the flavor of a more general theorem of Duistermaat [D] on restricting moment maps to the fixed-point sets of antisymplectic involutions. In fact Duistermaat's theorem does not apply directly, because the subset where d is smooth (and a moment map) is noncompact; in any case we preferred to give a polygon-theoretic proof.

3) When $k = 3$ Theorem 5.1 guarantees that the bending torus acts simply transitively on the fiber over an interior point of Γ_m , making this fiber a torus $U(1)^{m-3}$ (or $O(1)^{m-3}$ when $k = 2$). Over a prodigal boundary point of Γ_m , the fiber is still a product of 0- or 1-spheres, but fewer of them.

4) Bending around other diagonals than the ones above can be done in the same way, the moment map lifted to $\mathbf{V}_2(\mathbf{C}^m)$ being the difference of the two eigenvalues of M^*M for a corresponding submatrix M of $(a, b) \in \mathbf{V}_2(\mathbf{C}^m)$. For instance, we take

$$M = \begin{pmatrix} a_2 & b_2 \\ a_3 & b_3 \\ a_4 & b_4 \end{pmatrix}$$

for the diagonal $\partial_{2,4} := \rho(2) + \rho(3) + \rho(4)$. The bending flows around two diagonals $\partial_{p,q}$ and $\partial_{p',q'}$ commute if and only if the pairs $\{p, q\}$ and $\{p', q'\}$ intersect or are unlinked in $\mathbf{R}/m\mathbf{Z}$.

6. TORIC MANIFOLD STRUCTURES ON ${}^m\mathcal{P}_+(\alpha)$ FOR $m = 4, 5, 6$

In this section, we study examples of $\mathcal{P}_+(\alpha) \subset {}^m\mathcal{P}^3$ such that the $m - 3$ diagonal functions $d_2, \dots, d_{m-2} : \mathcal{P}_+(\alpha) \rightarrow \mathbf{R}$ never vanish. The whole space $\mathcal{P}_+(\alpha)$ consists of prodigal polygons and, by §5, the bending flows give an action of a big (i.e. half-dimensional) torus on $\mathcal{P}_+(\alpha)$. By Delzant's theorem (see [De], or [Gu, §1]), we can construct from the moment polytope Δ_α alone a toric manifold which is equivariantly symplectomorphic to the space $\mathcal{P}_+(\alpha)$. This can be achieved also by [DJ, §1.5], though only up to equivariant diffeomorphism. The latter also gives the real part, the planar polygon space $\mathcal{P}^2(\alpha)$, as a 2^{m-3} -sheeted branched cover of Δ_α . We sum up below some results of these constructions without writing all the details.

Without explicit mention of the contrary, α is supposed to be generic. Contrary to the previous sections, we do not require that the perimeter of our polygons is 2. It was necessary to fix the perimeter in order to define the map ℓ and the value 2 is the natural choice to deal with the map $\Phi : \mathbf{V}_2(\mathbf{C}^m) \rightarrow {}^m\tilde{\mathcal{P}}^k$. But ${}^m\mathcal{F}^k(\alpha)$ makes sense for any $\alpha \in \mathbf{R}_{\geq 0}^m$ and so do the various moduli spaces ${}^m\mathcal{P}^k(\alpha)$, etc. When $\sum \alpha_i = 2$, the polytope Δ_α is a slice through the Gel'fand-Cetlin moment polytope Γ_m of §5: for general α it is a homothetic copy of this section.

(6.1) $m = 4$: The condition which guarantees that d_2 never vanishes is $\alpha_1 \neq \alpha_2$ or $\alpha_3 \neq \alpha_4$. The space of quadrilaterals ${}^4\mathcal{P}_+(\alpha)$ is then a compact toric manifold of dimension 2, therefore diffeomorphic to $\mathbf{C}P^1$. The moment map d_2 has image the interval $\Delta_\alpha := I_1 \cap I_2$ where

$$I_1 := [|\alpha_1 - \alpha_2|, \alpha_1 + \alpha_2] \quad \text{and} \quad I_2 := [|\alpha_4 - \alpha_3|, \alpha_4 + \alpha_3].$$

The space ${}^4\mathcal{P}^2(\alpha)$ is $\mathbf{R}P^1$. The quadrilateral spaces ${}^4\mathcal{P}^2(\alpha)_+$ have long since been classified (see for instance [Ha]). One has

$${}^4\mathcal{P}^2(\alpha)_+ = \begin{cases} S^1 \sqcup S^1 & \text{when } I_1 \subset I_2 \text{ or } I_2 \subset I_1 \\ S^1 & \text{otherwise} \end{cases}.$$

Observe also that α is generic if and only if the boundaries of the intervals I_1 and I_2 do not meet.

By the Duistermaat-Heckman Theorem [Gu, §2], the symplectic volume of ${}^4\mathcal{P}^3(\alpha)$ is equal to the length of Δ_α . We would then obtain the same length if we had used the other diagonal $|\rho(2) + \rho(3)|$. This produces a statement of elementary Euclidean geometry: the variation intervals of the two diagonals of a quadrilateral with given sides in \mathbf{R}^3 are the same length.

(6.2) $m = 5$: Conditions for which both d_2 and d_3 never vanish are for instance $\alpha_1 \neq \alpha_2$ and $\alpha_4 \neq \alpha_5$. The space of pentagons ${}^5\mathcal{P}_+(\alpha)$ is then a toric manifold of dimension 4. The moment polytope $\Delta_\alpha \in \mathbf{R}^2$ for (d_2, d_3) is the intersection of the rectangle I_α

$$I_\alpha := [|\alpha_1 - \alpha_2|, \alpha_1 + \alpha_2] \times [|\alpha_5 - \alpha_4|, \alpha_5 + \alpha_4]$$

with the non-compact rectangular region

$$\Omega_\alpha := \{(x, y) \in (\mathbf{R}_{\geq 0})^2 \mid x + y \geq \alpha_3 \text{ and } y \geq x - \alpha_3 \text{ and } y \leq x + \alpha_3\}.$$

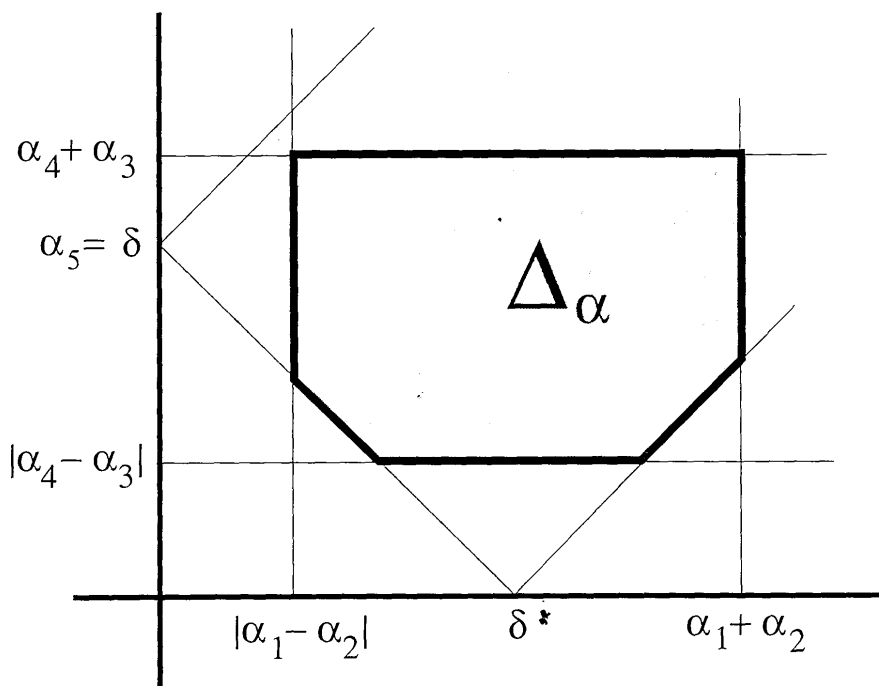

FIGURE 2: The moment polytope Δ_α

(see Figure 2). One sees that Δ_α has at most 7 sides. The generic α are exactly those for which the boundary of Ω_α contains no corner of I_α and ${}^5\mathcal{P}_+(\alpha)$ is then obtained by symplectic blowings up from $\mathbf{C}P^2$ or $S^2 \times S^2$. The space of planar polygons ${}^5\mathcal{P}_+(\alpha)$ is a closed surface obtained by gluing 4 copies of Δ_α and its Euler characteristic is given by the formula

$$\chi({}^5\mathcal{P}^2(\alpha)) = 4 - \# \text{ (sides of } \Delta_\alpha)$$

(see [DJ], Example 1.20) and is orientable if and only if $I_\alpha \subset \omega_\alpha$. One has of course $\chi({}^5\mathcal{P}_+^2(\alpha)) = 2\chi({}^5\mathcal{P}^2(\alpha))$ and ${}^5\mathcal{P}_+^2(\alpha)$ is an orientable surface (${}^m\mathcal{P}_+^k(\alpha)$ is always orientable). The possible cases, depending on the number of sides of Δ_α , are summed up in the following table.

# of sides	$\mathcal{P}_+^3(\alpha)$	$\mathcal{P}^2(\alpha)$	$\mathcal{P}_+^2(\alpha)$	Ex. of α
3	\mathbf{CP}^2	\mathbf{RP}^2	S^2	(2,1,5,1,2)
4	a) $\mathbf{CP}^2 \# \overline{\mathbf{CP}^2}$	Klein bottle	T^2	(3,2,5,1,2)
	or b) $S^2 \times S^2$	T^2	$T^2 \sqcup T^2$	(3,1,3,1,3)
5	$(S^2 \times S^2) \# \overline{\mathbf{CP}^2}$	$T^2 \# \mathbf{RP}^2$	Σ_2	(2,1,3,1,2)
6	$(S^2 \times S^2) \# 2\overline{\mathbf{CP}^2}$	$T^2 \# 2\mathbf{RP}^2$	Σ_3	(2,1,1,1,2)
7	$(S^2 \times S^2) \# 3\overline{\mathbf{CP}^2}$	$T^2 \# 3\mathbf{RP}^2$	Σ_4	(4,3,4,3,4)

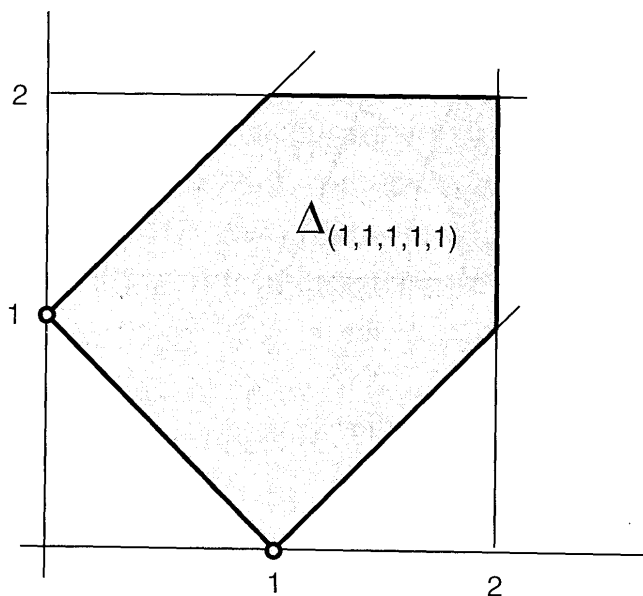

FIGURE 3: $\Delta_{(1,1,1,1,1)}$

(6.3) Some embeddings of the regular pentagon $\alpha = (1, 1, 1, 1, 1)$ are not prodigal. However none are lined and thus the moduli space $V_0 := {}^5\mathcal{P}^3(\alpha)$ is diffeomorphic for small ε to V_ε where $V_\varepsilon := {}^5\mathcal{P}^3(\alpha_\varepsilon)$ and

$\alpha_\varepsilon := (1 + \varepsilon, 1, 1, 1, 1 + \varepsilon)$. The moment polytope for α_ε has then 7 sides and thus $V_0 \simeq V_\varepsilon$ is diffeomorphic to $(S^2 \times S^2) \# 3\overline{\mathbf{CP}^2}$ (if $k = 2$, ${}^5\mathcal{P}^2(\alpha)_+ \simeq \Sigma_4$). The “limit moment polytope” $\Delta_{(1,1,1,1,1)}$ is shown in Figure 3.

The pre-image in V_ε of the segments $\{x = \varepsilon\} \cap \Delta'_\alpha$ and $\{y = \varepsilon\} \cap \Delta'_\alpha$ are 2-spheres of symplectic volume proportional to ε , by the Duistermaat-Heckman Theorem. Passing to the limit V_0 , these spheres become Lagrangian, and so cannot be complex. This shows that the action of the bending torus is not complex — these polygon spaces are only equivariantly symplectomorphic, not equivariantly isometric, to toric varieties.

(6.4) Any class $r \in {}^5\mathcal{P}^{k=2,3}(\alpha)$ has a unique representative in $\rho \in {}^5\tilde{\mathcal{P}}^k(\alpha)$ with $\rho(5) = (-\alpha_5, 0, 0)$ and $\gamma(r) := \rho(1) + \rho(2)$ in the half-plane $\mathcal{H} = \{z = 0, y \geq 0\}$. This provides a map $\gamma : {}^5\mathcal{P}^3(\alpha) \rightarrow \mathcal{H}$ whose image Δ_α is the intersection $R_1 \cap R_2 \cap \mathcal{H}$ where R_1 and R_2 are the rings

$$R_1 := \{v \in \mathbf{R}^2 \mid |\alpha_1 - \alpha_2| \leq |v| \leq \alpha_1 + \alpha_2\},$$

$$R_2 := \{v \in \mathbf{R}^2 \mid |\alpha_4 - \alpha_3| \leq |v| \leq \alpha_4 + \alpha_3\}.$$

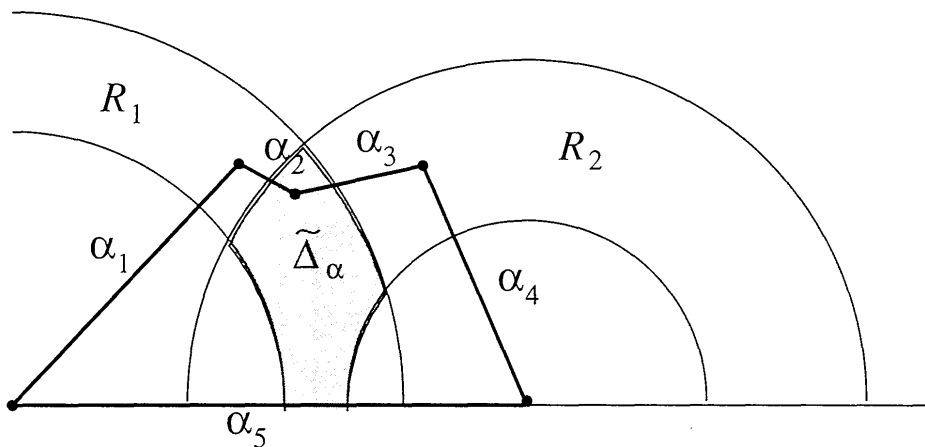

FIGURE 4: $\tilde{\Delta}_\alpha$

The idea of reconstructing ${}^5\mathcal{P}^2(\alpha)$ by gluing copies of $\tilde{\Delta}_\alpha$ goes back to the early works of W. Thurston on planar linkages (see [TW, p.100]). The relationship with our theory is the following: the domain $\tilde{\Delta}_\alpha$ is straightened up into a PL-polytope Δ_α in \mathbf{R}^2 by the map $v \mapsto (|v|, |v - (0, \alpha_5)|)$ and Δ_α is just the moment polytope for the bending Hamiltonians $\partial_1(\rho) = |\rho(1) + \rho(2)|$ and $\partial_2(\rho) = |\rho(3) + \rho(4)|$.

(6.5) $m = 6$: The conditions $\alpha_1 \neq \alpha_2$ and $\alpha_5 \neq \alpha_6$ imply that d_2 and d_4 never vanish. However, one cannot guarantee generically $d_3 \neq 0$. But we can replace the $d = (d_1, d_2, d_3)$ by $\delta := (\partial_1, \partial_2, \partial_3)$ where

$$\partial_1 := d_1 = |\rho(1) + \rho(2)|, \quad \partial_2 := |\rho(3) + \rho(4)|, \quad \partial_3 := d_3 = |\rho(5) + \rho(6)|$$

and guarantee non-vanishing of the δ_i 's by the generic condition $\alpha_{2i-1} \neq \alpha_{2i}$. Observe that $\partial_i \circ \Phi : \mathbf{V}_2(\mathbf{C}^m) \rightarrow \mathbf{R}$ ($i = 1, 2, 3$) are the functions on $\mathbf{V}_2(\mathbf{C}^m)$ given (on $(a, b) \in \mathbf{V}_2(\mathbf{C}^m)$) by the difference of the eigenvalues of the (2×2) -matrices $M_i^* M_i$, where

$$M_1 := \begin{pmatrix} a_1 & b_1 \\ a_2 & b_2 \end{pmatrix} \quad M_2 := \begin{pmatrix} a_3 & b_3 \\ a_4 & b_4 \end{pmatrix} \quad M_3 := \begin{pmatrix} a_5 & b_5 \\ a_6 & b_6 \end{pmatrix}.$$

The moment polytope in \mathbf{R}^3 is the intersection of the rectangular parallelepiped

$$I_\alpha := [|\alpha_1 - \alpha_2|, \alpha_1 + \alpha_2] \times [|\alpha_4 - \alpha_3|, \alpha_4 + \alpha_3] \times [|\alpha_6 - \alpha_5|, \alpha_6 + \alpha_5]$$

with the region

$$\Omega := \{(x, y, z) \in \mathbf{R}^3 \mid 0 \leq z \leq x + y, \quad 0 \leq x \leq y + z \text{ and } 0 \leq y \leq x + z\}.$$

The domain Ω can be described as the convex hull of the three half-lines

$$\{0 \leq x = y \text{ and } z = 0\}, \quad \{0 \leq y = z \text{ and } x = 0\}, \quad \{0 \leq z = x \text{ and } y = 0\}$$

or the cone $\mathbf{R}_+ \cdot \Xi_3$ on the hypersimplex Ξ_3 . The polytope Δ_α has then at most 9 facets. The length-system α is generic when the boundary of Ω does not contain corners of I_α . As 6 is even, the regular hexagon is not generic: ${}^6\mathcal{P}^1(1, \dots, 1)$ contains 10 elements.

(6.6) The bending flows ∂ occurring in (6.4) and 6 admit the following generalization. For $m = 2n - 1$ or $2n$, we define the *even-step* map $e : {}^m\mathcal{F}^k \rightarrow {}^n\mathcal{F}^k$ by $e(\rho)(i) := \rho(2i - 1) + \rho(2i)$ taking $e(\rho)(n) := \rho(m)$ if m is odd. We also call e the induced maps ${}^m\tilde{\mathcal{P}}^k \xrightarrow{e} {}^n\tilde{\mathcal{P}}^k$, ${}^m\mathcal{P}_+^k \xrightarrow{e} {}^n\mathcal{P}_+^k$ and ${}^m\mathcal{P}^k \xrightarrow{e} {}^n\mathcal{P}^k$. We call $\rho \in {}^m\mathcal{F}^k$ *even generic* if $e(\rho)$ is a proper polygon. Above the space of proper polygons, the map e is a smooth locally trivial bundle whose fiber is a product of $(k - 1)$ -spheres. Define $\partial = (\partial_1, \dots, \partial_n) : {}^m\mathcal{F}^k \rightarrow \mathbf{R}^n$ by $\partial := \ell \circ e$. The map ∂ gives the side lengths of the new polygon $e(\rho)$. It is always continuous and smooth when $e(\rho)$ is a proper polygon. As the map e is a submersion on even-generic polygons, the critical values of ∂ are the same as those of ℓ , the walls of 4.3. As for the map ℓ , the map ∂ can be defined on each ${}^m\mathcal{P}^k(\alpha)$. Call $\alpha \in \mathbf{R}^m$ *even generic* if ${}^m\mathcal{P}^k(\alpha)$ only consists of even-generic polygons. For instance, α is even-generic if $\alpha_{2i-1} \neq \alpha_{2i}$ for all i . When $k = 3$, ∂ is a moment map for the corresponding bending action of T^n defined on even-generic polygons.

Restrict to ${}^m\mathcal{P}^3(\alpha)_+$ for an even-generic α . Define the right-angled polytope

$$I_\alpha := \prod_{i=1}^n [|\alpha_{2i} - \alpha_{2i-1}|, \alpha_{2i} + \alpha_{2i-1}]$$

and consider the convex polytope $\Delta_\alpha \subset \mathbf{R}^n$

$$\Delta_\alpha := \begin{cases} I_\alpha \cap (\mathbf{R}_+ \cdot \bar{\mathbf{E}}_n) & \text{when } m = 2n \\ I_\alpha \cap (\mathbf{R}_+ \cdot \bar{\mathbf{E}}_n) \cap \{x_n = |\rho(m)|\} & \text{when } m = 2n - 1 \end{cases}$$

PROPOSITION 6.7. 1) The image of $\partial : {}^m\mathcal{P}^k(\alpha)_+ \longrightarrow \mathbf{R}^n$ is the whole polytope Δ_α .

2) If $x \in \Delta_\alpha$ is a regular value of ∂ , the even-step map e induces, for $m = 3$, a symplectomorphism from the symplectic reduction $T^n \setminus \partial^{-1}(x)$ onto ${}^n\mathcal{P}_+^k(x)$. \square

7. REMARKS AND OPEN PROBLEMS

(7.1) Is there an octonionic version of Section 3? Alternately, are there $U_1(\mathbf{H})$ bendings in dimension 5 (like the $U_1(\mathbf{C})$ bending flows in dimension 3 and $U_1(\mathbf{R})$ flippings in dimension 2)?

(7.2) Observe that the inclusion ${}^m\mathcal{P}^k \subset {}^m\mathcal{P}^{k+1}$ becomes a bijection when $k \geq m - 1$ (triangles are always planar, etc.). In what ways are these spaces ${}^m\mathcal{P}^{m-1}$ more natural than the unstable ones?

(7.3) The m -polygons whose first diagonal is of a given length forms a sphere bundle over a space of $(m - 1)$ -polygons. (For $k = 3$ this is just symplectic reduction by the first bending circle.) This gives an inductive way to construct the space of m -polygons by gluing together (sphere bundles over) the spaces of $(m - 1)$ -polygons; it would require identification of these sphere bundles, which in $k = 3$ might be done using the Duistermaat-Heckman theorem (where the circle bundle is determined by its Euler class).

Alternately one might work out the fibers of the whole map d of section 5. Unfortunately in dimensions above 3 these are always singular (at, in particular, the planar polygons).

(7.4) In [KM1] and [Wa] there are presented “wall-crossing arguments” for identifying the spaces ${}^m\mathcal{P}^2(\alpha)$. It would be nice to relate these to a combination of [Du] and the paper [GS2], which presents its own wall-crossing arguments for any symplectic reduction by a torus.

(7.5) A space of great interest nowadays is the moduli space of flat $SU(2)$ connections on a punctured Riemann sphere — in the language of this paper, geodesic polygons in S^3 (rather than \mathbf{R}^3). The spaces here can be seen as limiting versions where the radius of S^3 goes to infinity. We do not know how to adapt the Gel'fand-MacPherson correspondence to this case; one definite complication is that it is no longer the symmetric group but the braid group which permutes the edges, and that action is not complex.

(7.6) By averaging the Riemannian metric with respect to the bending torus, one can deform the complex structure on a space of prodigal polygons to that of the corresponding toric variety. Is the original complex structure that of a toric variety (not just in the same deformation class)?

REFERENCES

- [Au] AUDIN, M. *The topology of torus actions on symplectic manifolds*. Birkhäuser, 1991.
- [DJ] DAVIS, M. and T. JANUSZKIEWICZ. Convex polytopes, Coxeter orbifolds and torus actions. *Duke Math. J.* 62 (1991), 417–451.
- [De] DELZANT, T. Hamiltoniens périodiques et image convexe de l'application moment. *Bull. Soc. Math. France* 116 (1988), 315–339.
- [Du] DUISTERMAAT, J. J. Convexity and tightness for restrictions of Hamiltonian functions to fixed-point sets of an antisymplectic involution. *Trans. AMS* 275 (1983), 417–429.
- [Fr] FRANKLIN, J. *Matrix theory*. Prentice-Hall, 1968.
- [GGMS] GEL'FAND, I., M. GORESKY, R. MACPHERSON and V. SERGANOVA. Combinatorial geometries, convex polyhedra and Schubert cells. *Adv. Math.* 63 (1987), 301–316.
- [GM] GEL'FAND, I. and R. MACPHERSON. Geometry in Grassmannians and a generalization of the dilogarithm. *Adv. Math.* 44 (1982), 279–312.
- [Gu] GUILLEMIN, V. *Moment maps and combinatorial invariants of Hamiltonian T^n -spaces*. Birkhäuser, 1994.
- [GS1] GUILLEMIN, V. and S. STERNBERG. The Gelfand-Cetlin system and quantization of the complex flag manifolds. *J. Funct. Anal.* 52(1) (1983), 106–128.
- [GS2] GUILLEMIN, V. and S. STERNBERG. Birational equivalence in the symplectic category. *Inventiones Math.* 97 (1989), 485–522.
- [Ha] HAUSMANN, J.-C. Sur la topologie des bras articulés. In “Algebraic Topology, Poznan”. *Springer Lectures Notes* 1474 (1989), 146–159.
- [HK] HAUSMANN, J.-C. and A. KNUTSON. The cohomology ring of polygon spaces. Preprint (1997). <http://www.unige.ch/math/biblio>
- [Ho] HOPF, H. Über die Abbildungen der dreidimensionalen Sphäre auf die Kugelfläche. *Math. Annalen* 104 (1931), 637–665.

- [KM1] KAPOVICH, M. and J. MILLSON. The symplectic geometry of polygons in the Euclidean plane. *J. Diff. Geometry* 42 (1995), 430–464.
- [KM2] KAPOVICH, M. and J. MILLSON. The symplectic geometry of polygons in Euclidean space. *J. Diff. Geometry* 44 (1996), 479–513.
- [Ki] KIRWAN, F. *Cohomology of quotients in symplectic and algebraic geometry*. Princeton University Press, 1984.
- [Kl] KLYACHKO, A. Spatial polygons and stable configurations of points in the projective line, in: *Algebraic geometry and its applications (Yaroslavl, 1992)*, *Aspects Math.*, Vieweg, Braunschweig (1994), 67–84.
- [Mo] MONTGOMERY, R. Heisenberg and isoholonomic inequalities: “How to use dual pairs to ignore the rest of the universe”. *Symplectic geometry and mathematical physics*. Souriau Volume. Birkhäuser, 1991.
- [Th] THIMM, A. Integrable geodesic flows on homogeneous spaces. *Ergodic theory and dynamical systems I* (1980), 495–517.
- [TW] THURSTON, W. and J. WEEKS. The mathematics of three-dimensional manifolds. *Scientific American* 251 (1984), 94–107.
- [Wa] WALKER, K. Configuration spaces of linkages. Undergr. Thesis, Princeton (1985).

(Reçu le 20 octobre 1996; version révisée, le 10 février 1997)

Jean-Claude Hausmann

Mathématiques-Université
C.P. 240
CH-1211 Genève 24
Switzerland
hausmann@math.unige.ch

Allen Knutson

MSRI
1000 Centennial Drive
Berkeley, Ca 94720
U.S.A.
allenk@alumni.caltech.edu